

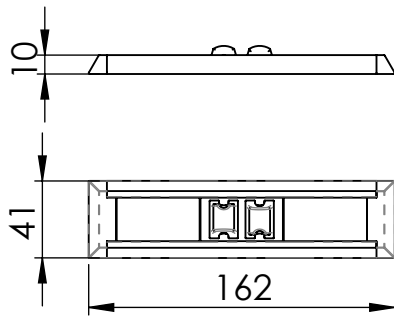

KURMA-L

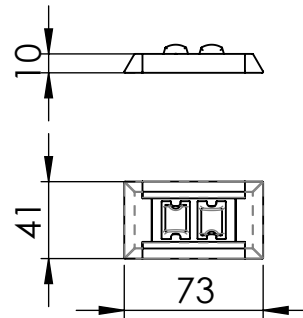

KURMA-S



Linsen am Beispiel KURMA-S
Alle Linsen sind auch für
KURMA-L möglich

Varianten

Flächenbeleuchtung bis
6m Höhe

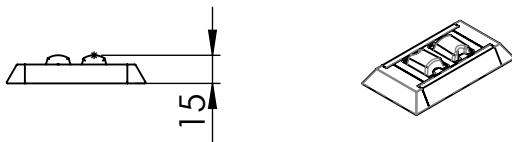

Wegbeleuchtung bis
6m Höhe

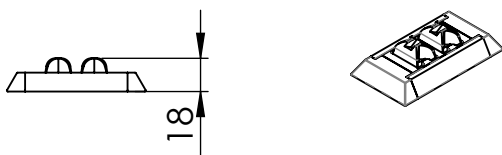

Flächenbeleuchtung LEDIL (A) bis
3m Höhe

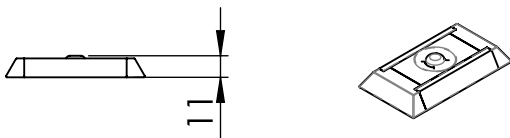

Wegbeleuchtung LEDIL (B) bis
3m Höhe

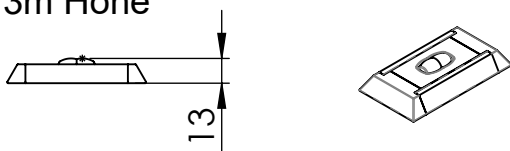

Zum Anschrauben an
Avatara Gehäuse

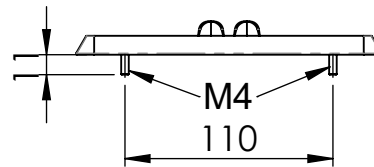

zum Aufsteckeln
auf Leuchtstoffröhren

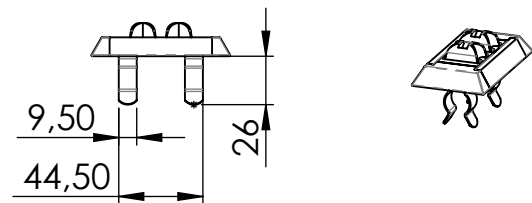

zum Einbau in Hohldecken

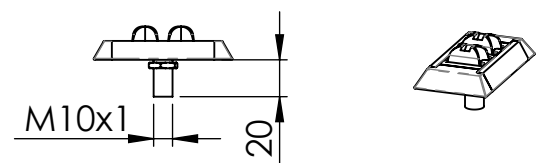



Versionen

Einzelbatterie
AX-Version

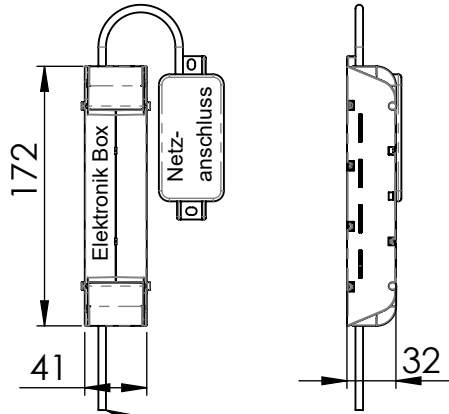

Zentralbatterie
E-220

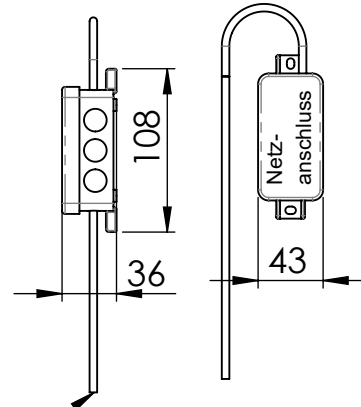

Leitung zur Leuchte
KURMA

Einzelbatterie

ZM3-LN

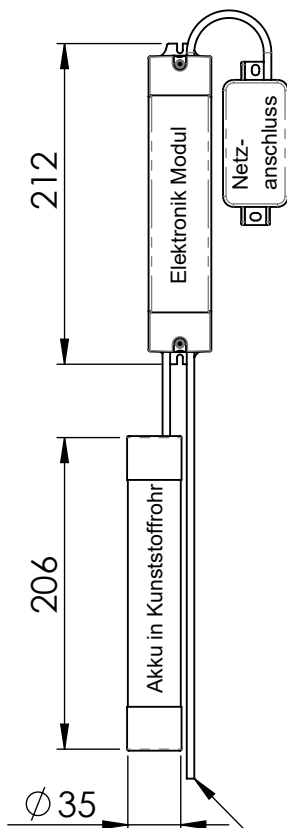

Zentralbatterie

E-110/E-024-060

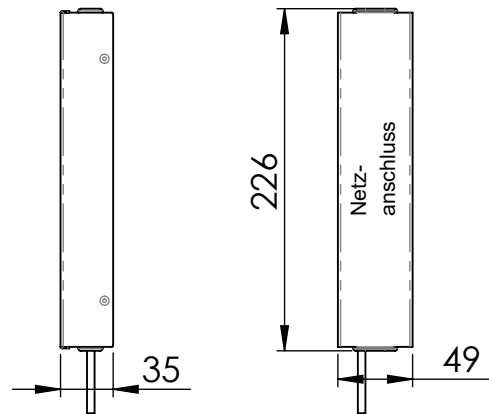

Zentralbatterie
mit Überwachungsbaustein

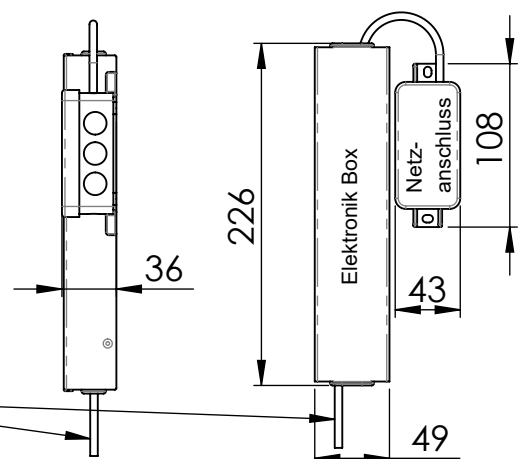

Leitung zur Leuchte
KURMA