

ARUNA LED Sicherheitsleuchte



für Einbau in Hohldecken

Einzelbatterie

ZM3-LN

B

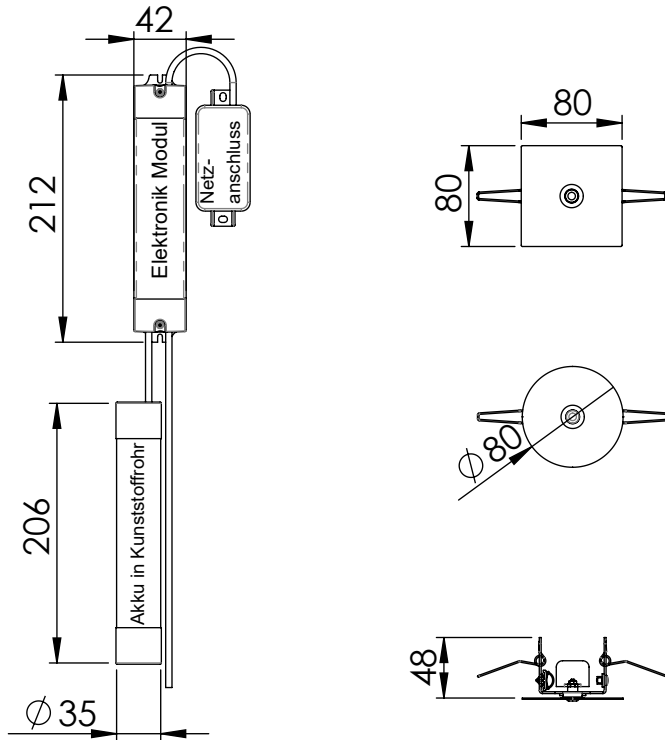

AX-Version

A

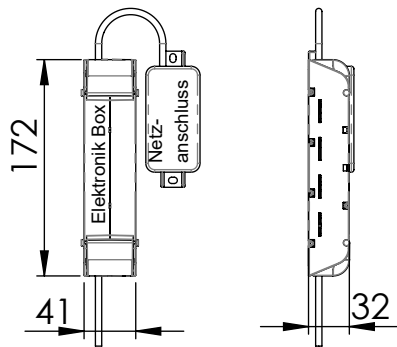

Zentralbatterie

E-110/E-24-60

B

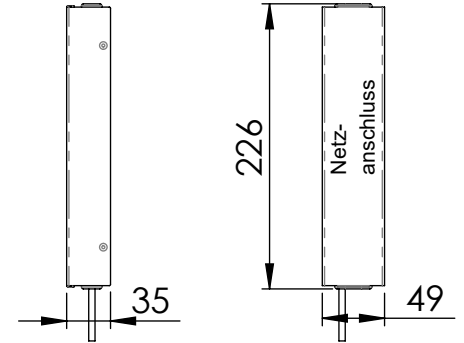

E-220

A

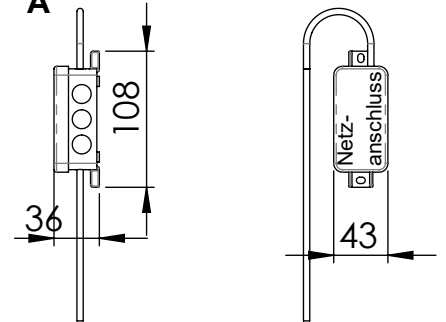

mit Überwachungsbaustein

B

